

Care Instructions for your AquaPace Aquanomic Tap

-5 litre/min (+0%/-20%)

To maintain the appearance of this tap, ensure that it is regularly cleaned using only a clean, soft damp cloth. A solution of warm water and a mild liquid detergent may be used where necessary, and then the fitting rinsed thoroughly and wiped dry.

Any other cleaning action could invalidate your warranty.

You **MUST NOT** use abrasive cleaners, scouring and acidic cleaners under any circumstances as this **WILL** damage the integrity of the surface finish. Avoid contact with all solvents (including chlorinated solvents, ketones or acetones) as these may result in surface deterioration or etching. Also avoid contact with any harsh household chemicals such as oven cleaners, drain cleaners, rust removers, paint strippers and Stainless-Steel cleaner.

Important Technical Data:

- Min / Max operating pressure: **1 bar - 4 bar***
- Recommended / Maximum hot water temperature: **46 - 70°C***
- Tap hole size and centres: **Ø35mm**

*If these temperatures or pressures are exceeded, even for short periods, damage can result. In these instances, a thermostatic mixing or pressure reducing valve should be installed.

- This product is either WRAS approved or manufactured in accordance with recognised European standards.
- Please ensure that your kitchen mixer is fitted in accordance with Local Water Byelaws.
- Hot and cold supply pressures should be as closely balanced as possible for best results.
- Supply pipes should maintain the maximum diameter until immediately before the fitting.
- Always use the manufacturer's tail pipes provided – use of non-manufacturer tails will invalidate warranty.
- The differential between the hot and cold water temperatures should be sufficient to allow correct mixing function.
- This tap has been 100% assembly tested therefore, you may expect a small residual amount of water to remain in the tap or inner packaging when delivered. This is normal and any water marks can be removed using the care advice above.
- This product is installed with Neoperl™ water saving technology; this will reduce your water consumption to a **maximum of 5 litres a minute (mixed) regardless of the incoming water pressure**, this is designed to reduce the amount of water wasted during everyday use and meets current UK building guidelines. Should the flow regulator after the valve exit become blocked with debris or require maintenance it can be cleaned then replaced. The Graph shows typical water consumption in litres per minute at various input pressure ranges.
- Where the tap has a removable aerator on the spout exit it can be removed and cleaned periodically with water to maintain optimum flow performance.

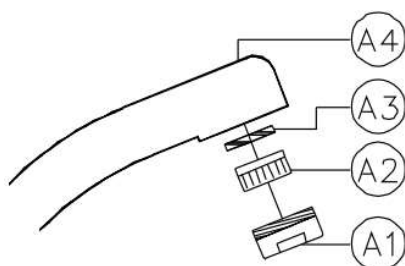

1. Holding the spout (A4) using an adjustable or 22mm spanner unscrew the aerator case (A1)
2. Push the aerator (A2) out from the centre of the aerator case (A1)
3. If the aerator (A2) is blocked due to Limescale deposits, we recommend soaking the aerator in vinegar to loosen the scale, and an old toothbrush to clear away any debris.
4. Reassemble the tap in the reverse order making sure that aerator case (A1) is screwed on.

Care Instructions for your AquaPace Aquanomic Tap

-5 litre/min (+0%/-20%)

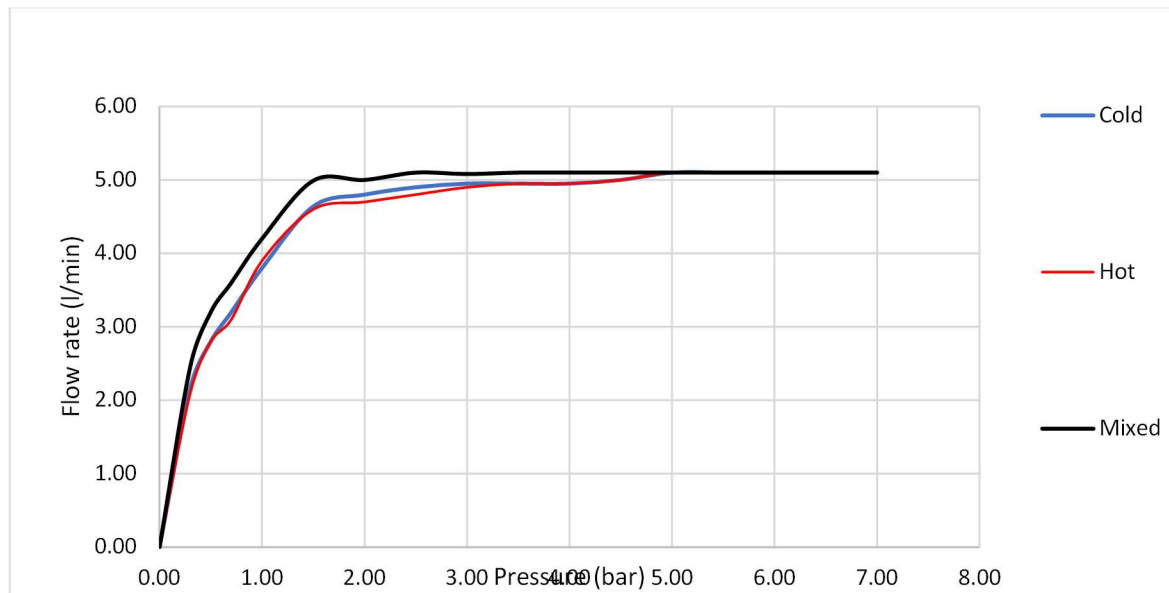

5 Year Warranty Terms and Conditions

In the event of any problem or defect in the materials or workmanship of your new Leisure mixer within FIVE years of purchase, the purchaser's sole remedy shall be the replacement (at the manufacturer's discretion) of all or any part of the product that is defective. All working parts, valves and O rings are guaranteed for a period of FIVE years from purchase. Chrome decorative surface finishes are guaranteed for FIVE years from the date of purchase and other decorative finishes (including granite finishes, matt black, satin steel, satin bronze) are guaranteed for THREE years from date of purchase. The warranty extends to the original purchaser only.

You should retain a copy of your dated invoice as proof of purchase to validate any claims under this guarantee as claims without proof of purchase may not be accepted. Surface scratches and marks caused through careless or improper installation or accidental damage are **NOT** covered by this warranty. Any product returns must be packaged with all associated tap parts and clear details of the installation name and address and the customer service number displayed on the return packaging.

IMPORTANT: All warranties extend only to mixers used for normal domestic use in the UK or Ireland and that the care, installation and maintenance instructions have been fully observed.

Due to our continual product development, we may not be able to provide an identical replacement for a defective product throughout the guarantee period. Where an identical product is no longer available, we will supply the nearest equivalent from our then current product range. In assessing your claim, we must be given the opportunity to inspect the product as installed prior to removal.

No other warranties, express or implied, are made, including merchantability or fitness for a particular purpose. Under no circumstances shall the manufacturer be liable for any loss or damage arising from the purchase, use or inability to use this product, or for any special, indirect, incidental, or consequential damages. No liability is accepted for consequential damage to other household fixtures, fittings or furnishings arising from this claim, even if attached to the product. No installer, dealer, agent or employee of Aga Rangemaster Limited has the authority to modify the obligations or limitations of this warranty.

Care Instructions for your AquaPace Aquanomic Tap

-5 litre/min (+0%/-20%)

Installation Preparation:

All parts should be removed from their packaging and inspected for completeness and transit damage prior to installation. **IMPORTANT:** Before installation, it is **essential** that you thoroughly flush through the supply pipes in order to remove any remaining dirt, solder, swarf, sediment or impurities from your water system. Failure to carry out this simple procedure could cause significant damage to the workings of the tap, reduce flow rates and invalidate the warranty. We recommend installing isolation valves to both the hot and cold feed pipes in an accessible position. This will help to ease any future required maintenance to the product.

- Shut off the water heating system and ensure that the mains stopcock is closed.
- Ensure both hot and cold-water supplies are isolated before commencing installation.
- If replacing an existing tap, remove the tap & clean the end of the feed pipes using wire wool, the tap hole areas should be free from dirt and sealant. You should ensure that the product will both fit into the depth of the mounting surface available and reach the required outlet positions before installation.
- Loosely position the tap to check if any alteration to the existing pipework is required, if this is the case do this now.

Installation:

IMPORTANT:

Note that the handle moves 45° left (hot) and 45° right (cold) of the centre (mixed water) position. Decide on the required alignment of the tap handle to the sink bowls and the relevant resting position of the spout (see fig 1 for a suggested alignment). Note also that the spout is designed to rotate 360°.

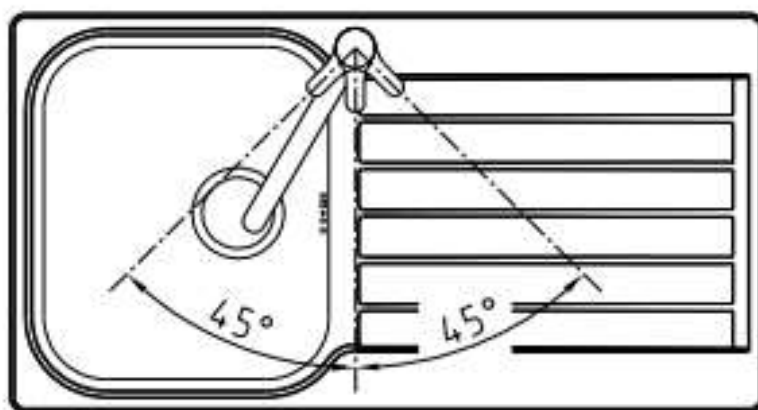

Fig 1

1. Screw the fixing stud (C) into the base of the tap (A)
2. Screw the tail pipes (G & H) into the base of the tap (A), note the hot water should be connected to the left of the tap when viewed from the front.
3. Pass the upper seal (B) over the studded rod (C) and tail pipes (G & H) and onto base of the tap body (A).
4. Place the mixertap (A) onto the sink or worktop and pass the tail pipes (G & H) and fixing stud (C) through the taphole. With the tap in place check that the tail pipes (G & H) meet the hot and cold-water feeds. If further adjustment to the plumbing is required do this now.
5. Pass the lower gasket (D) and then metal horseshoe (E) over the fixing stud (C) and around tail pipes (G & H).
6. Fasten fixing nut (F) securely onto the fixing stud (C) fixing the tap into its correct location centred over tap hole.
7. **IMPORTANT:** Once the tap is secured in position **do not** attempt to adjust the alignment of the tap by gripping and twisting the tap body (A) or the handle; doing so could loosen the tap assembly or break the valve. Always loosen fixing nut (F) before re-aligning the tap
8. Connect the tail pipes (G & H) to the water supplies using ½" BSP x 15mm compression fittings or similar. Note the tail Pipes (G & H) can be 'doglegged' to allow more space to attach fittings.

Care Instructions for your AquaPace Aquanomic Tap

-5 litre/min (+0%/-20%)

Pack Contents:

Key	Description:	Qty
A	Mixertap body	1
B	Upper sink/ worktop seal	1
C	Studded rods	1
D	Rubber washer	1
E	Metal horseshoe	1
F	Fixing nut	1
G	½" Hot flexible tail pipe with integral check valve	1
H	½" Hot flexible tail pipe with integral check valve	1
I	Non return valves	2
J	Mesh filters	2

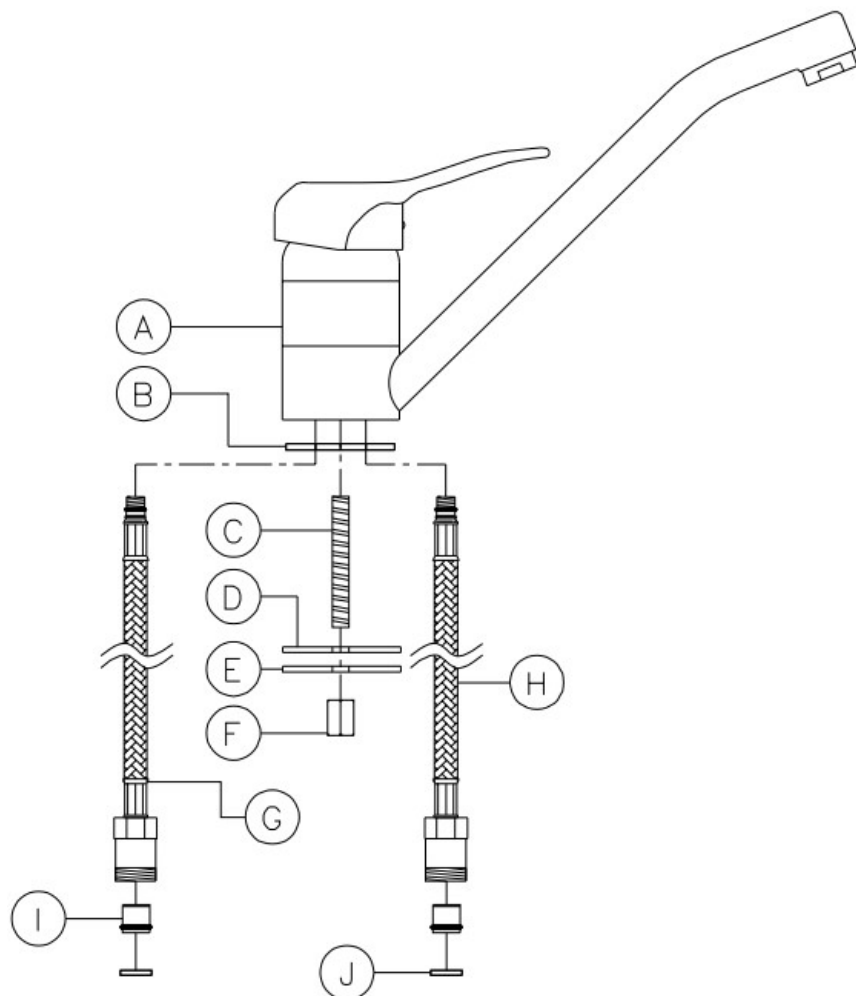

After installation:

Once you have visually checked the installation of the new tap and all connections, turn the tap handles off then turn on both the hot and cold-water supplies to check for leaks on all connections.

Turn on your water heating system and ensure that your mains stopcock is open. Now check the function of flow and function of hot, cold and mixed water. Turn off the tap and check carefully for any leaks around all connections on the fitting and adjoining plumbing. If possible, return to the installation after a longer period to double check for slower leaks. If pressure testing equipment is available check the installation to the maximum recommended pressure.

Clean the tap to remove any marks created during installation as instructed then place a bag over the product to protect the tap until it is ready for use. The installation should be periodically checked for damage, if the property is left unattended for a prolonged period, we recommend isolating water supplies.