

# STAINLESS STEEL INSET SINK WITH FIXED POSITION CLIPS

## Suitable for Atlanta, Euroline Plus and Linear Double Bowl Installer

Please leave this leaflet with the user, as it contains valuable after care advice.

### Notes

- ⚠ Please take care of sharp metal edges before and during installation.
- ⚠ During installation, take care to protect the sink from scuffs and scratches.
- ⚠ Avoid straining and overtightening of all plumbing fixtures connected to the sink.
- ⚠ Carefully check that the moulding and edges of the sink are dead level so that water will flow off the drainer.
- ⚠ We recommend that the worktop opening is sealed using waterproof sealant, paint or a similar material.
- ⚠ The clamping brackets are suitable for worktops of between 20 – 35 mm thickness. If your worktop is a different size then it may require packing under the clips or rebating.

## Installation

### Marking out the opening

1. We recommend that you fit the inset sink to the worktop before permanently fixing the worktop to the cabinet.
2. Place the sink upside down on the worktop. Position the sink on the worktop as required. Make sure the cabinet framework will clear all parts of the sink. Using a soft, sharp pencil draw around the sink as accurately as possible (**Fig.1**). Remove the sink.

#### Alternatively 2 (where supplied)

Position the cut-out template on the worktop (**Fig.2**). Make sure the cabinet framework will clear all parts of the sink. Using a soft, sharp pencil draw around the template as accurately as possible. Remove the template.

3. Draw another line 10 mm inside the sink top outline – this is the cutting line for the opening.
4. Drill as large a hole as possible inside the cutting line. Using a padsaw, jigsaw or similar, cut out the opening up to the cutting line.

### Fitting the seal or sealant

There are 3 methods of sealing your sink to the worktop:

- Fitting the seals to the sink
- Fitting the foam tape to the worktop
- Applying silicon sealant to the sink

#### Fitting the seals to the sink

Remove the paper backing from the main seal (**Fig.3**). Apply the main seal to the underside of the sink (**Fig.4**).

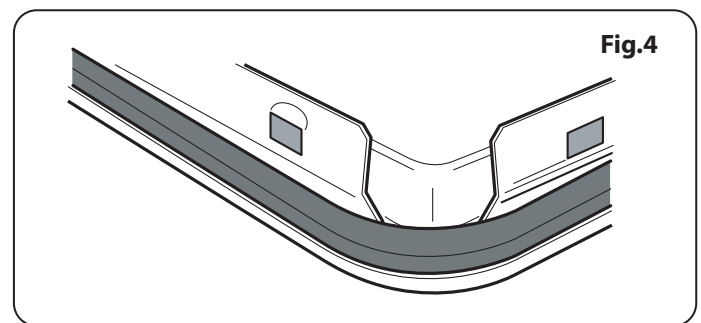
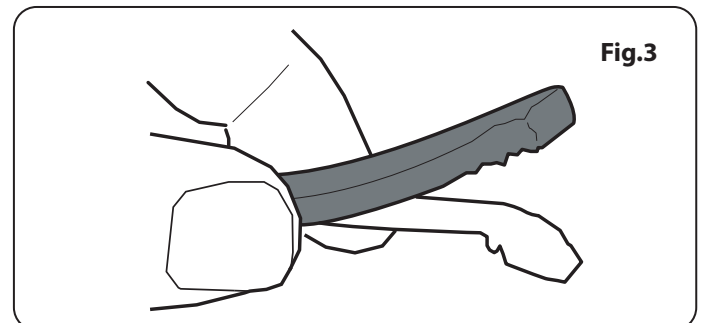
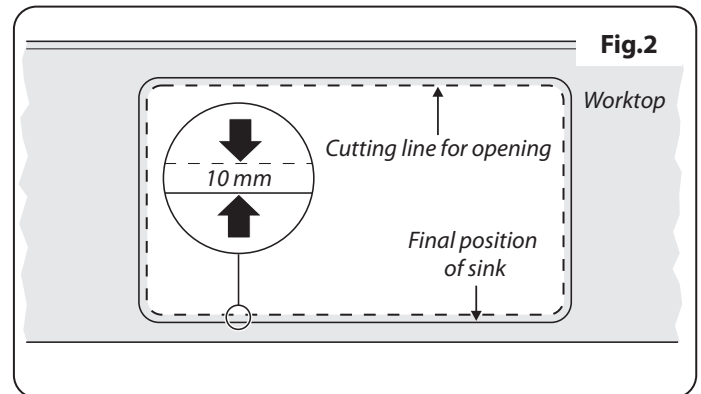
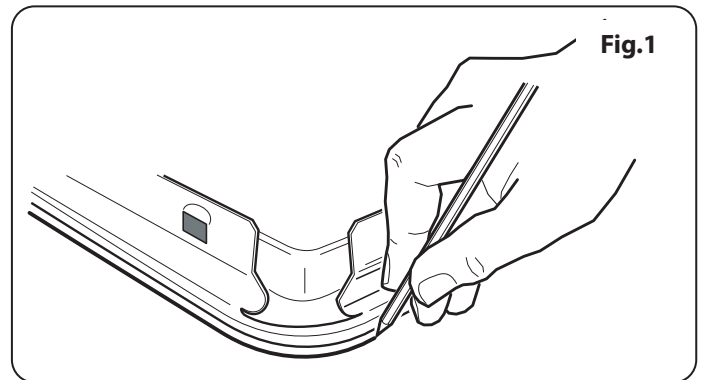

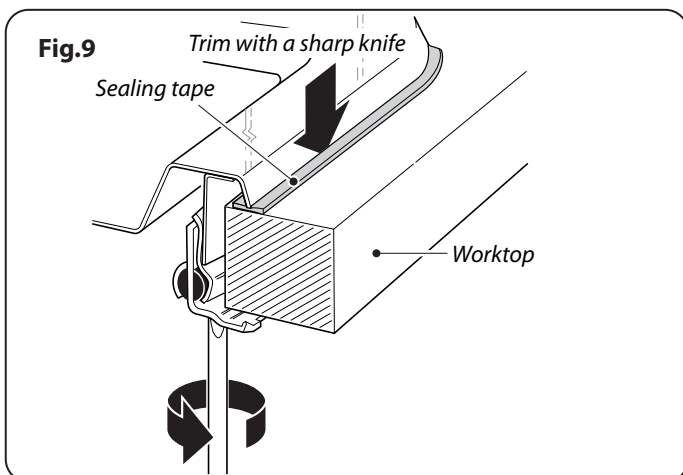
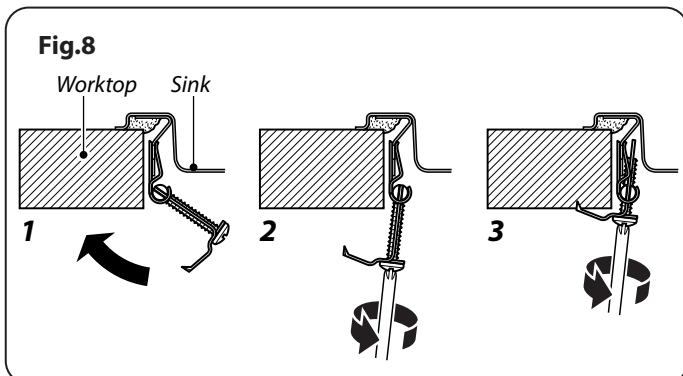
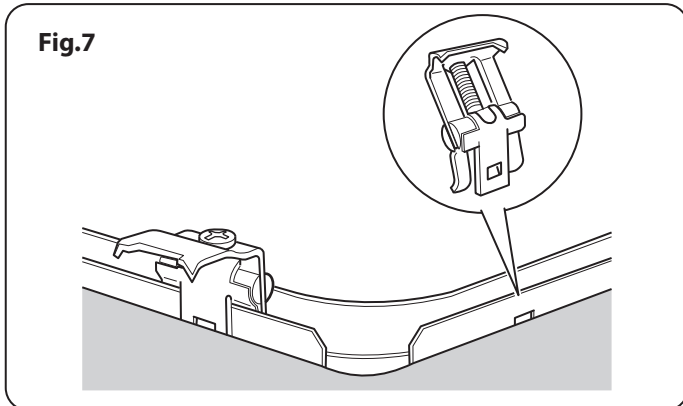
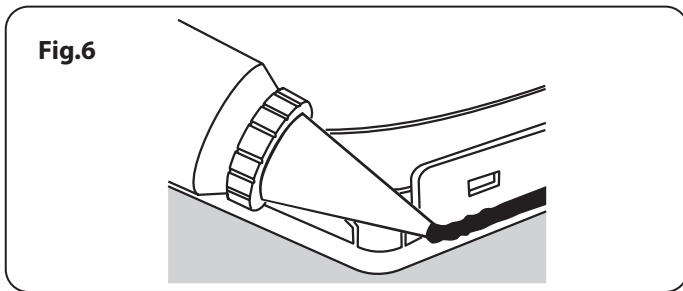
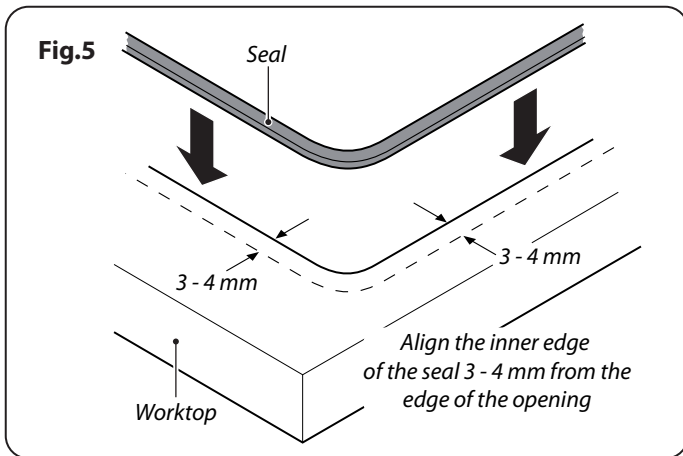

### Fitting the foam tape to the worktop

1. Remove the paper backing from the foam tape. Apply the tape to the worktop, making sure to line up the inner edge of the tape 3 – 4 mm from the edge of the cut (**Fig.5**).
2. Make sure to apply the seal all the way around the opening, finishing with a neat butt joint (if required, the tape may be slightly stretched to obtain this).

**Note:** The worktop should be clean and dry before applying the tape.

### Applying silicon sealant to the sink

Apply silicone sealant (not supplied) to the underside of the sink rim (**Fig.6**).

### Fitting the sink

1. Attach the fixing clips to the sink rail in the positions shown in **Table 1**. Make sure that the two 'prongs' of the clip face inwards (**Fig.7**). Open the hinge on the clip.
2. Turn the sink upside down and lay the worktop over the sink. Swing each clip into place (**Fig.8**) – this is the most effective method, although if the worktop has been fitted to the cabinet the sink can be placed in the opening and fixed in position from underneath.
3. Centre the sink. Tighten the fixing screws in the sequence shown in **Table 1**.

**⚠ Do not tighten fully at first attempt.**

**⚠ Do not overtighten the clips as this may distort the sink rim.**

4. Remove any surplus sealing material or wipe away any excess sealant.

# Clip positions and recommended tightening sequence

## 12 clips

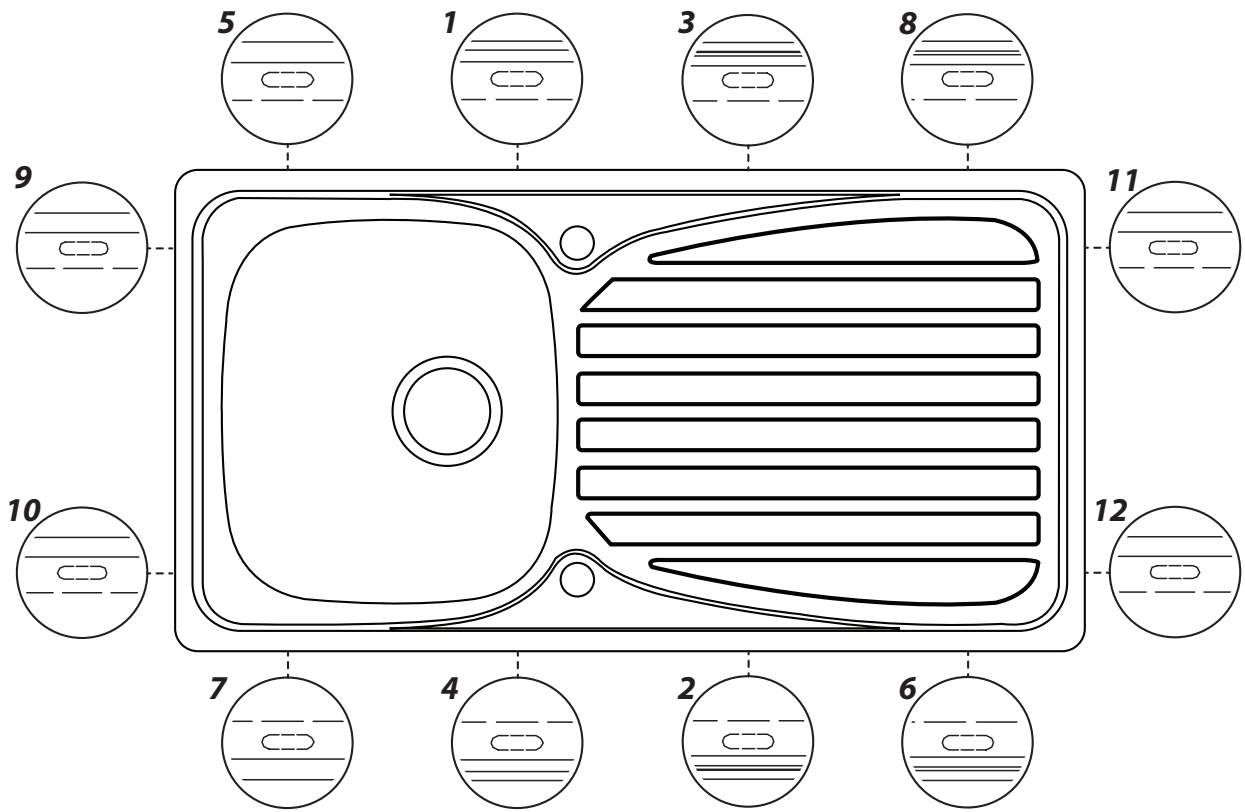

## 14 clips

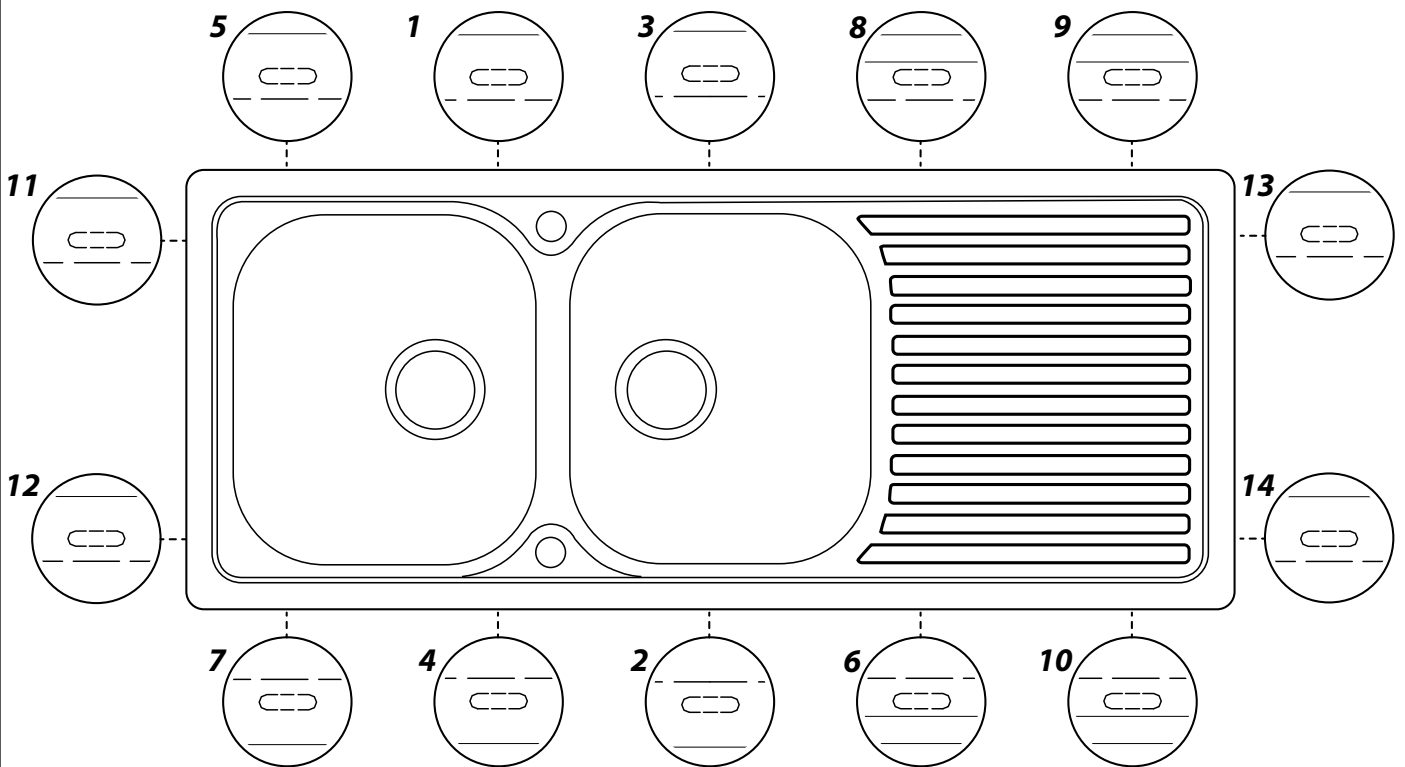

All dimensions in mm

Table 1

# After Care Stainless Sinks

## Day-to-day care

Routine cleaning of your stainless steel sink is easy if the following simple procedure is followed:

After use wipe the bowl and drainer with a soft damp soapy cloth and rinse with clean water. In hard water areas, an application of proprietary cream cleaner or stainless steel sink cleaner will avoid any build-up of a dull film of waterborne deposits.

Although stainless steel is an extremely durable material and will withstand a great deal of hard use, it can be scratched by hard or sharp objects. If the surfaces are to be kept in a blemish free condition reasonable care should be taken when handling such items.

## Cleaning

Always use a soft cloth. The use of coarse grit scouring powders or soap-filled wire wool cleaning pads is not recommended, since both will mark the surface of the sink. Wire wool pads can leave tiny fragments of wire embedded in the surface and these can rust and leave small brown rust stains. Vigorous rubbing with a soft cloth with a proprietary cream cleaner or stainless steel sink cleaner will remove these stains.

Always remove wet cleaning aids (cloths, containers, etc.) from the sink surface after use to avoid the formation of water marks and rust stains.

## Discolouration and heavy staining

In most cases, staining of stainless steel is due to something being deposited on the steel rather than an attack on the material itself. The most common cause of staining is the build-up of a thin film of waterborne deposits on the sink surface, often first seen as a rainbow effect. The build-up of such a film can be avoided by drying the surface of the sink after use.

Should such a film appear, apply proprietary cream cleaner or stainless steel sink cleaner neat and rub vigorously with a damp cloth along the length of the sink surface. After cleaning, rinse thoroughly with clean water and dry.

Wire wool products and ferrous water supply pipes can leave minute ferrous particles adhered to the sink surface. Since stainless steel under normal conditions does not rust, these particles can cause the appearance of small brown rust stains. These stains can be removed using the procedure described above.

### 10 Year Guarantee

We guarantee to replace any stainless steel sink that breaks due to material or manufacturing defects within 10 years from the date of purchase.

The guarantee does not cover normal wear and tear occurring through use of the product.

For the guarantee to apply the owner must follow the use, care and cleaning instructions provided.

Accessories and waste fittings are not included in this guarantee.

## Caution!

**Certain household products contain substances that will attack the stainless steel surface. They are:**

### 1. Bleaches

Most common domestic bleaches contain Chlorine in the form of a hypochlorite. Chlorine attacks the microscopic Chromium Oxide film on the surface and can cause pitting of the surface.

Bleaches should always be used in the prescribed strength specified by the manufacturers. Undiluted bleaches can cause pitting and staining of the surface and should be immediately rinsed off with plenty of clean water.

All cleaning agents containing hypochlorites are unsuitable for use with stainless steel and, even highly diluted, can cause pitting under certain circumstances. For this reason we strongly recommend that the sink is not used for soaking clothes or cleaning clothes in hypochlorite solutions for long periods.

### 2. Silver dip cleaners

These are particularly harmful since they contain strong acids that can cause discolouration and pitting. The first sign of this is an iridescent rainbow stain that turns an etched dull grey colour.

Should any silver dip cleaner come into contact with the surface of the sink it should be immediately rinsed off with plenty of clean water.

### 3. Corrosive foodstuffs

Fruit juices, damp salt, vinegar, ready made mustards, pickle and mayonnaise can cause pitting and corrosion if left in contact with the stainless steel surface for long periods.

### 4. Acids

Sulphuric, Hydrochloric and other strong acids will cause pitting corrosion, as will photographic developing liquids. If contact occurs immediately wash off with plenty of clean water.



Meadow Lane, Long Eaton,  
Nottingham, NG10 2GD, England  
Tel: 0115 946 4000

E-mail: [consumers@agarangemaster.co.uk](mailto:consumers@agarangemaster.co.uk)  
[www.leisuresinks.co.uk](http://www.leisuresinks.co.uk)



23

EN 13310 : 2015

Kitchen sink made of: Stainless Steel  
Cleanability: Pass  
Load resistance: NPD / N/A  
Durability: Pass

Due to our policy of continual improvement, we reserve the right to change specifications without prior notice.