

Stainless Steel Inset Sinks with T-nut Fixing

1. With soft sharp pencil, mark final position of sink top, by measurement, on the work top allowing for clearance of cabinet frame work.
2. Place sink-top in correct position on worktop then reverse front to rear, not end for end.

With sharp soft pencil draw round sink as accurately as possible making sure that this outline coincides with final position marked previously.



3. Remove sink top and mark another line 20mm inside the sink top outline, following the corner radii with care.

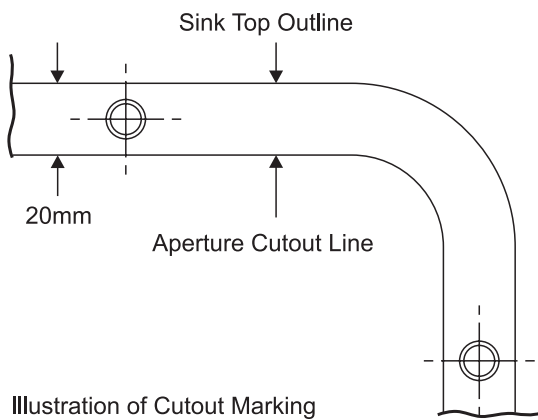

This is the cutting line for the aperture.

4. Drill as large a hole as possible inside the cutting line. Using a pad saw, jig saw or similar, cut out the aperture to the cutting line.
5. The sink should then be placed in the aperture where it will rest on the T-Nuts. The T-Nuts should be marked round carefully with a pencil making sure that the sink is parallel to the worktop edge.

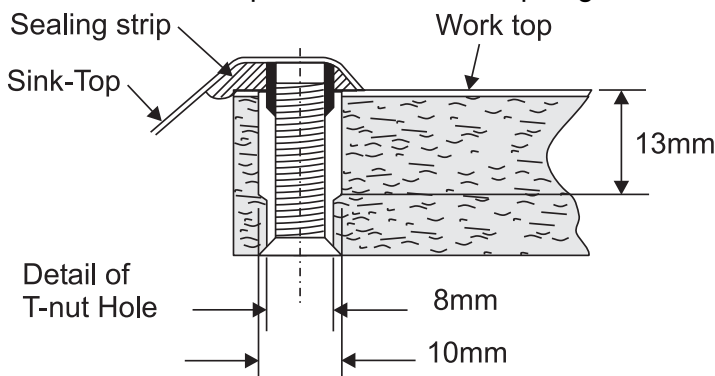

6. The sink is then removed and a 8mm hole is drilled on the centre of each T-Nut position, countersunk on the underside of the worktop and counterbored from the top with a 10mm diameter drill 13mm deep to accept the T-Nut.

7. The sinktop should then be placed in position to check for final fitting.
8. Turn the sink upside down and fill the outer perimeter with a suitable sealing compound, (Bostik Glazing Compound, Prestik Sealing Compound and Arborseal have been found suitable). The sealing compound should be sufficient to fill the rim but any excess should be pressed down with a warm knife so that it is evenly spread around the sink perimeter.
9. Now fit the sink to the worktop, firmly in position and press down evenly if possible using heavyweights around the perimeter. Enter the screws and screw gently home. The weights will cause the sealing compound to settle to the profile of the sink perimeter, and the screws will need to be tightened slowly and gently or distortion of the sink perimeter will result from too great a local pressure. After one hour remove the weights and dress off any surplus compound from around the sink flange, with a wooden or plastic spatula, taking care not to damage the plastic laminate.
10. After twenty-four hours, check the tightness of the T-Nuts but do not over-tighten. If the fixing screw bottoms because of over length, remove and hacksaw 12mm from end of thread, and refit.

Recommended tightening sequence for sink fixing clips

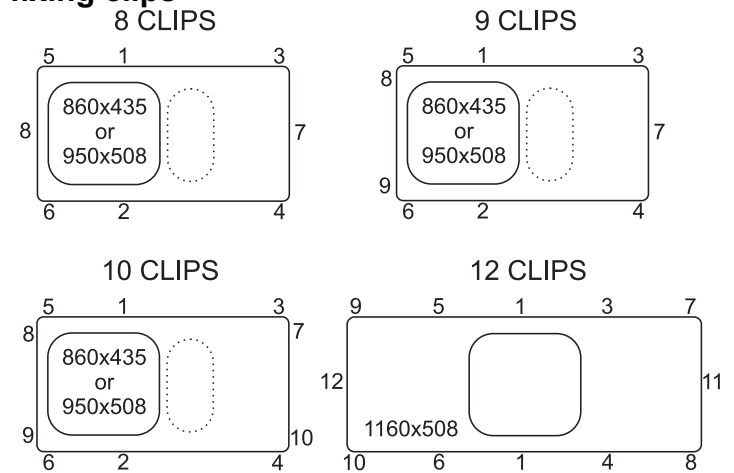

After Care Stainless Sinks

Day to Day Care

Routine cleaning of your stainless steel sink is easy if the following simple procedure is followed. After use wipe the bowl and drainer with a soft damp soapy cloth, rinse with clean water. In hard-water areas, an application of Jif will avoid any build-up of dull film of waterborne deposits. Although stainless steel is an extremely durable material and will withstand a great deal of hard use, it can be scratched by hard or sharp objects. If the surfaces are to be kept in a blemish free condition reasonable care should be taken when handling such items.

Discolouration and Heavy Staining

Staining of stainless steel in most cases is due to something being deposited on the steel rather than an attack on the material itself. The most common cause of staining is the build up of a thin film of water borne deposits on the sink surface, often first seen as a rainbow effect. The build up of such a film can be avoided by drying the surface of the sink after use as described above. However, should such a film appear, it can be readily removed with a soft damp cloth and Jif. To remove the film, apply the Jif neat and rub vigorously with a damp cloth along the length of the sink surface. After cleaning rinse thoroughly with clean water and dry. Wire wool products and ferrous water supply pipes can leave minute ferrous particles adhered to the sink surface. Since stainless steel under normal conditions does not rust, these particles can cause the appearance of small brown rust stains. These stains can be removed using the procedure described above.

CAUTION :

Certain household products contain substances which will attack the stainless steel surface, they are :

1. Bleaches :

Most common domestic bleaches contain Chlorine in the form of a hypochlorite. Chlorine attacks the microscopic Chromium Oxide film on the surface and can cause pitting of the surface. Bleaches should always be used in the prescribed strength specified by the manufacturers. Undiluted bleaches can cause pitting and staining of the surface and should be immediately rinsed off with plenty of clean water. All cleaning agents containing hypochlorites are unsuitable for use with stainless

steel and, even highly diluted, can cause pitting under certain conditions. For this reason it is strongly recommended that the sink is not used for soaking clothes or cleaning clothes in hypochlorite solutions for long periods.

2. Silver Dip Cleaners :

These are particularly harmful since they contain strong acids which can cause discolouration and pitting. The first sign of this is an iridescent rainbow stain which turns an etched dull grey colour. Should any Silver Dip Cleaner come into contact with the surface of the sink it should be immediately rinsed off with plenty of clean water.

3. Corrosive Foodstuffs :

Fruit juices, damp salt, vinegar, readymade mustards, pickle and mayonnaise can cause pitting and corrosion if left in contact with the stainless steel surface for long periods.

4. Acids:

Sulphuric, Hydrochloric and other strong acids will cause pitting corrosion, as will photographic developing liquids. All should be immediately washed off with plenty of clean water if contact occurs.

Cleaning :

Always use a soft cloth. The use of coarse grit scouring powders or soap filled wire wool cleaning pads is not recommended, since both will mark the surface of the sink. Wire wool pads can leave tiny fragments of wire embedded in the surface and these can rust and leave small brown rust stains. Vigorous rubbing with a soft cloth, JIF, neat detergent, cleaning cream or liquid will remove these stains. Always remove wet cleaning aids (cloths, containers, etc.) from the sink surface after use in order to avoid the formation of water marks and rust stains.