

Luxe Inset Sinks Fitting Instructions

1. It is recommended that the Inset sink is fitted to the worktop before being permanently fixed to the cabinet.
2. Place the sink upside down on worktop. Position the sink relative to the worktop as required, ensuring that the cabinet framework will be clear of all parts of the sink.
With sharp soft pencil draw round sink as accurately as possible. See fig. 1.
3. Remove the sink and draw another line 10mm inside the outline of the sink top following the corner radii with care. This is the cutting line for the aperture.

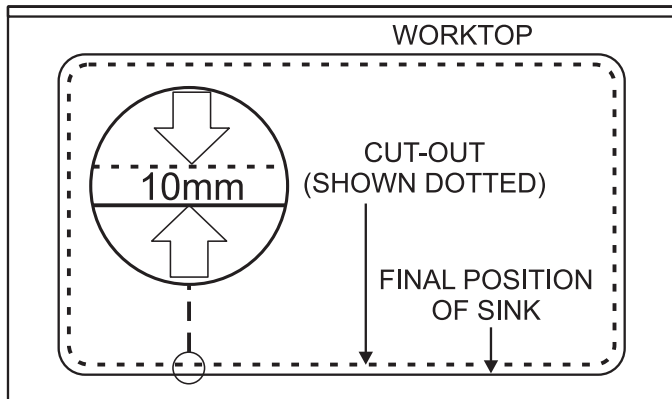

Fig. 1

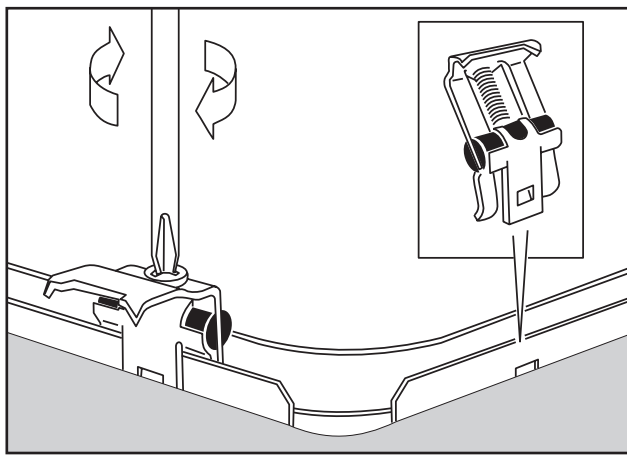

Fig. 3

4. Drill as large a hole as possible inside the cutting line. Using a pad saw, jig saw or similar, cut out the aperture to the cutting line.
5. Remove paper backing from the foam tape and stick down to the worktop, lining up the inner edge of the tape 3 to 4mm from the edge of the cut, see fig. 2. A neat butt joint of the two ends is desirable. The tape may be stretched slightly to obtain this. The worktop should be clean and dry before application.
6. Attach the fixing clips to the sink rail as shown in fig. 3 ensuring that the two 'prongs' of the clip face inwards.

Open the hinge on the clip.

7. Turn the sink upside down and lay the worktop over the sink. Swing the clip into position. (This is the most effective method although if the worktop has been fixed to the cabinet, the sink can be placed in the aperture and the fixing effected from underneath).
8. With the sink secured in position the excess sealing tape should be cut off by carefully running a sharp knife or razor blade round the periphery of the sink and then lifting the excess tape away.

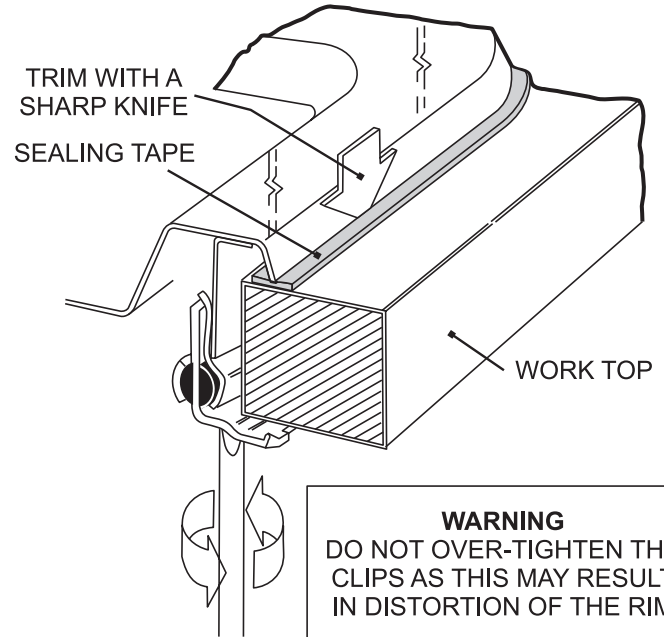
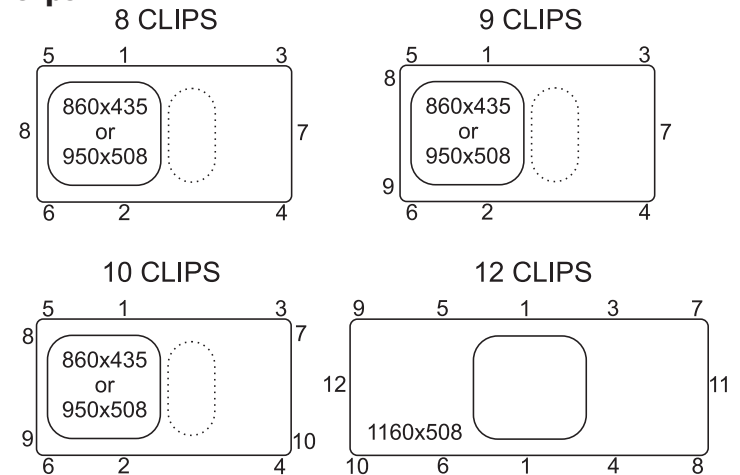

Fig. 2

NB The adjustment of the clamping bracket for U.K. market suits worktops of thicknesses 27mm to 43mm. Any variations from these thicknesses will either require packing under the clips or for the worktops to be rebated.

Recommended tightening sequence for sink fixing clips



After Care Stainless Sinks

Day to Day Care

Routine cleaning of your stainless steel sink is easy if the following simple procedure is followed

After use wipe the bowl and drainer with a soft damp soapy cloth, rinse with clean water. In hard-water areas, an application of Jif will avoid any build-up of dull film of waterborne deposits.

Although stainless steel is an extremely durable material and will withstand a great deal of hard use, it can be scratched by hard or sharp objects. If the surfaces are to be kept in a blemish free condition reasonable care should be taken when handling such items.

Discolouration and Heavy Staining

Staining of stainless steel in most cases is due to something being deposited on the steel rather than an attack on the material itself. The most common cause of staining is the build up of a thin film of water borne deposits on the sink surface, often first seen as a rainbow effect. The build up of such a film can be avoided by drying the surface of the sink after use as described above. However, should such a film appear, it can be readily removed with a soft damp cloth and Jif. To remove the film, apply the Jif neat and rub vigorously with a damp cloth along the length of the sink surface. After cleaning rinse thoroughly with clean water and dry. Wire wool products and ferrous water supply pipes can leave minute ferrous particles adhered to the sink surface. Since stainless steel under normal conditions does not rust, these particles can cause the appearance of small brown rust stains. These stains can be removed using the procedure described above.

CAUTION :

Certain household products contain substances which will attack the stainless steel surface, they are :

1. Bleaches :

Most common domestic bleaches contain Chlorine in the form of a hypochlorite. Chlorine attacks the microscopic Chromium Oxide film on the surface and can cause pitting of the surface. Bleaches should always be used in the prescribed strength specified by the manufacturers. Undiluted bleaches can cause pitting and staining of the surface and should be immediately rinsed off with plenty of clean water. All cleaning agents containing hypochlorites are unsuitable for use with stainless steel and, even highly diluted, can cause pitting under certain conditions. For this reason it is strongly recommended that the sink is not used for soaking clothes or cleaning clothes in hypochlo-

rite solutions for long periods.

2. Silver Dip Cleaners :

These are particularly harmful since they contain strong acids which can cause discolouration and pitting. The first sign of this is an iridescent rainbow stain which turns an etched dull grey colour. Should any Silver Dip Cleaner come into contact with the surface of the sink it should be immediately rinsed off with plenty of clean water.

3. Corrosive Foodstuffs :

Fruit juices, damp salt, vinegar, readymade mustards, pickle and mayonnaise can cause pitting and corrosion if left in contact with the stainless steel surface for long periods.

4. Acids :

Sulphuric, Hydrochloric and other strong acids will cause pitting corrosion, as will photographic developing liquids. All should be immediately washed off with plenty of clean water if contact occurs.

Cleaning :

Always use a soft cloth. The use of coarse grit scouring powders or soap filled wire wool cleaning pads is not recommended, since both will mark the surface of the sink. Wire wool pads can leave tiny fragments of wire embedded in the surface and these can rust and leave small brown rust stains. Vigorous rubbing with a soft cloth, JIF, neat detergent, cleaning cream or liquid will remove these stains. Always remove wet cleaning aids (cloths, containers, etc.) from the sink surface after use in order to avoid the formation of water marks and rust stains.